

Information and Communication Technology: Case of Using Petri Nets for Grain Delivery Simulation at Logistics System

Natalya Shramenko^{1,2[0000-0003-4101-433X]}, Olexiy Pavlenko^{3[0000-0003-4237-4310]} and Dmitriy Muzylyov^{4[0000-0002-8540-6987]}

¹ Kharkiv Petro Vasylenko National Technical University of Agriculture, Alchevskiyh Str. 44, 61002, Kharkiv, Ukraine

² Ukrainian State University of Railway Transport, Feierbakh Square 7, 61050, Kharkiv, Ukraine
nshramenko@gmail.com

³ Kharkiv National Automobile and Highway University, Yaroslava Mudrogo Str. 25, 61002, Kharkiv, Ukraine
ttpov@ukr.net

⁴ Kharkiv Petro Vasylenko National Technical University of Agriculture, Alchevskiyh Str. 44, 61002, Kharkiv, Ukraine
murza_1@ukr.net

Abstract. The paper is showing an example of applied use of modern information and communication technologies (ICT) in logistics. It was proved application expediency of this type of mathematical tools for the solution of the logistic problem on grain delivery based on Petri Nets analysis. It is shown the relevance using of information and communication technologies at such type when choosing the best delivery variant for export cargo turnover of grain freights. The statistics for export of this agricultural products category was presented. It demonstrates the annual growth for volumes of foreign sending. This fact gives prerequisites to using ICT for the successful solution of the considered problems. Interrelations at information exchange by participants of grain delivery were presented. The two-level representation structure for logistics system was described considering this fact. The visual scheme is developed for the system of information and communication technologies when transportation variants of grain cargo turnovers were simulated based on Petri Nets. The mathematical description is executed for operators used for modeling by a network. It is also presented visually network view for an assessment of delivery terms by time indicator. The histogram for three alternatives of a supply chain is designed with the help of simulation results. It allows choosing quickly the acceptable delivery scheme considering the minimum time of cargo turnover passing and, also accounting existence of transportation capacities during the concrete time period. This ICT considerably will accelerate the adoption for correct decision on the choice of a supply chain that minimizes expenses of the logistic companies when exporting the Ukrainian grain.

Keywords: Petri Nets, System, Logistics, Grain, Data, Information, Transport, Delivery, Simulation, Technology.

1 Introduction

The different and considerable data volumes appear in modern conditions at information saturation of society and various production spheres. This fact gives prerequisites for using computer technologies and intelligent systems for fast processing of information flow. Especially it is important to arrive at correct decisions in an operational period of planning for complex systems, such as the supply chain of agricultural cargoes. In particular, the logistic system of grain cargoes delivery has many communication links, including information, and, also consists of a significant elements amount. Therefore, there are some problems with effective management and creation of "correct time-table" of delivery from a production location to the place of its consumption [1-2]. There is a necessity to investigate the behavior of the studied system and to obtain information on its most important characteristics. The systems of parallel information processing and in parallel the functioning objects allow coming to the decision of problems connected with effective interaction of separate elements for the considered delivery system. The best example is the models based on Petri Nets theory [3].

Active information technology development allowed accelerating in recent years process of representation, processing, and use of information for cargo delivery system [4]. However, the companies sustain losses because of the untimely or doubtful obtained data on an operational situation at each link of a supply chain [5]. Today the attention is more and more paid to the information flow by means of which a material flow can be planed, operated and controlled [6]. Improvement of informational content and the organization quite often can bring a bigger effect, than technical innovations [7].

Today Ukraine carries out the biggest export of corn, barley, and wheat in the world (Fig.1) [8-9].

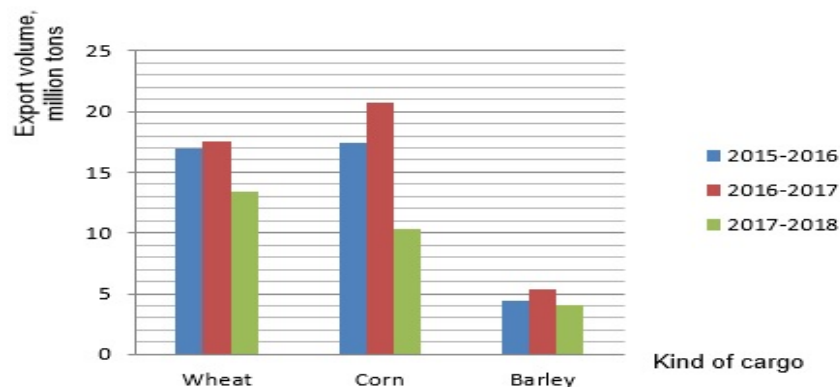

Fig. 1. Volume of the Ukrainian export grain at marketing period in 2015-2018 years

According to Fig.1 wheat was sent for export in bigger volume than others grain within the last year. Logistic costs, as a rule, include the expenses connected with transportation, warehousing, storage [10], loading and unloading operations, registration paperwork [11], cleaning, drying of cargoes, packing, safety and, also payment of any commission charges, tariffs, and taxes which connected with grain export. At the same time, delivery costs of grain cargoes exceed in Ukraine same tariffs at leading Europe countries (Fig. 2.). This explains the necessity of more flexible planning with the use of the modern systems which are based on information and communication technologies

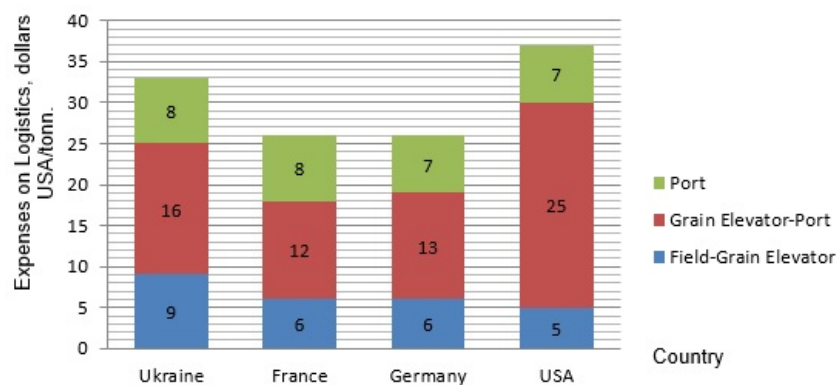

Fig. 2. Values of logistics costs per wheat delivery in different countries

The relevance of this research is also based on fact that in 2018 amount of cargo overloading in Ukrainian seaports reached 135.2 million tons. Due to the increase in cargo turnover according to four main nomenclatures which provide 71.4% of overloading: agricultural goods, ore, steel products, container transportation [12]. Thus, it is necessary to design models for logistic system of grain cargoes delivery from the producer to departure seaport and to carry out simulation for determination of impact level by obtaining information about forwarding material flow to the efficiency of decision adoption [13].

A modeling problem becomes simple when Petri Nets use. This tool can help to consider a bigger number of random factors which characterize any logistical systems during simulation. Thus, using such mathematical tools as Petri Nets reduces the probability of errors and failures emergence in a system. Therefore, the conducted modeling turns out the most adequate.

2 Literature Review

The approaches based on heuristic methods, own experience of managers and discipline of orders execution can be used now in goods transportation management in Ukraine. In practice it means emergence of the real losses connected with increase in cargo delivery period, idle times of cargo in wagons at "the abandoned trains" on

approaches to ports, boundary transitions and in warehouses of the enterprises (elevators), work arrhythmia for subsystems of transport and long investigations - "who is guilty". The sampling analysis for performance of cargoes delivery periods (based on data from the transportation document and calculated in the automated systems of normative delivery period) demonstrates what violations of term occurs when transporting (by all kinds) shipping at the level of 5%, container 32%, wagon carriage - 17% and group shipping - 8% [14]. Therefore, the logistics system of grain cargoes delivery should be considered from the viewpoint of the transport organization with delivery by trucks, railway wagons and with possibility using of containers [15] and piggyback traffic [16].

The simulation approaches quickly develops in recent years accounting active development of technologies at information processing. By the author in [17] was proved that imitating modeling of any events proceeding in active processes is relevant.

In recent years, many countries of the world made traceability compulsory procedure in a supply chain [18]. Management of cargo turnovers is represented as a difficult task for participants of a multimodal transport chain that is the main driving force in a supply chain [19].

The purpose of this work consists in offering the intelligent container tracking system for goods in the context of multimodal transportation: intelligent container tracking system for goods (i-TSCG). The tracking system of goods supply chain is proposed by several researchers because has many communications links and ensample factors. At the same time, models of the studied objects are optimized by using modern information systems and technologies [20-24].

Today neural networks are mainly used for the solution of optimization problems at logistics systems functioning as element-wise and in general [25-27]. They are applied at a stage of obtaining forecasting values to the further process organization. However, for their design it is necessary to have a bigger time series and to spend certain time for control (training) of network. At the same time tools based on Petri Nets [28, 29] allow to investigate behavior of an object in the real time mode at the expense of system productivity assessment (a time factor) [30-32] without forecast data.

3 Design of ICT for Grain Delivery Simulation (Research Methodology)

The article purpose is demonstration of applied using Petri Nets as bases of information and communication technologies for an operational decision for problems in logistical systems. In particular, for the choice of the best supply chains variant of grain cargoes from the sender to a seaport.

Creation of information systems demands system thinking. The logistics system structure of the enterprise and material flow providing logistics information systems are interconnected and interdependent. In order that information systems could provide the required efficiency of logistic processes, they should be integrated vertically and horizontally [33].

During the present time, the logistical system at grain cargoes delivery in Ukraine has the structure based on a participants' interaction: traders, as organizers of grain products export, producers, transport companies and, also the existing infrastructure of ports, railroads, highways networks (Fig.3).

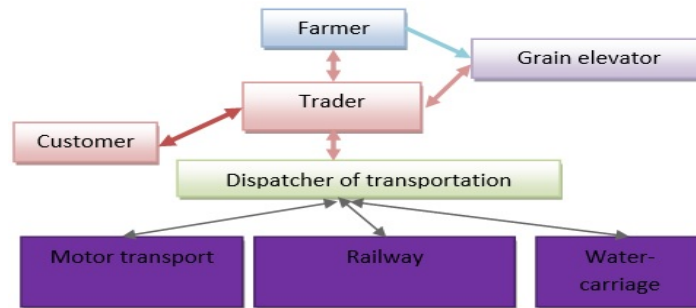

Fig. 3. The scheme of information exchange between participants in the logistical system

Traders in this scheme are the centralized system of necessary technological level which is directed to the organization of processes for participants and, also to receiving and the analysis of the data coming from a system for ensuring bigger transparency [34].

Such complete prospect is able in real time for all participants in a logistical system will allow traders to have enough opportunities for adoption of the relevant short-term and long-term decisions which will fit the organizer purpose and, also the purposes of all process. The system should be designed as two-level (Fig.4): on the top level — there are models of collecting and data processing, lower level — is presented by a simulation model about the functioning of a logistical system.

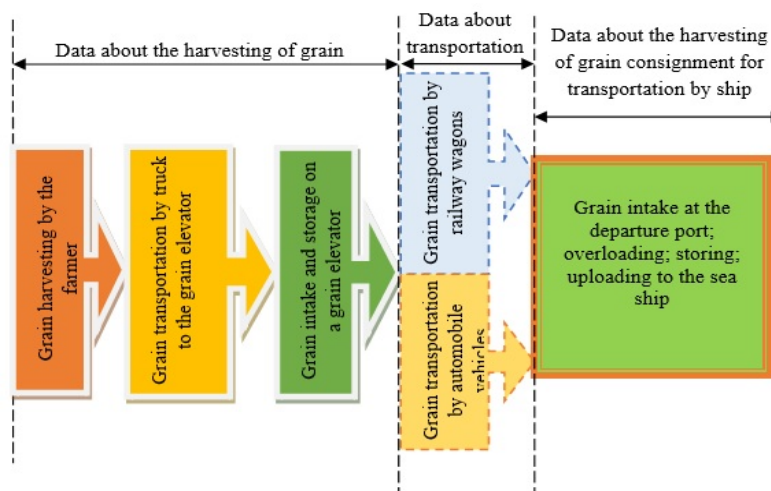

Fig. 4. Two-level representation of a logistical system at grain delivery

For ensuring work of the top level the advanced information technologies, such as technology of intelligent agents, data mining, big data, cloud computing (CC), the Internet of Things (IoT), RFID and Industry 4.0 technology which can be used for providing of data sharing and information on all supply chain can be used. [35-37].

The efficiency of functioning by a logistic system at the top level is defined by a three-element vector condition for forming the database about decision-making I_1, I_2, I_3 (Fig.4):

$$I_n = \{I_1, I_2, I_3\} \quad (1)$$

Each element is characterized by quantitative parameters N^i (mechanisms, vehicles, workers, technical means); by time which spent for performance of each technological operation, considering waiting and idle times – T^i ; by cost of work performance – C^i ; by receipt intensity at physical units (cargo, vehicles, mechanisms) – D^i ; by productivity of resources (technical means, workers) – P^i :

$$I_n = \{N_n^i, T_n^i, C_n^i, D_n^i, P_n^i\}, i = 1, \dots, k, \quad (2)$$

where each value is defined by the resources' quantity involved on i -th stage of technological operation to k -th maximum possible value.

The lower level is presented as a grain delivery process in a logistical system. We will carry out modeling of the considered real object at it. (Fig.5).

Petri Net is the evident and well-formalized behavior model of parallel systems with asynchronous interactions. It reflects the structure of the relationship between system elements and changing dynamics of its states in a compact form under the set entry conditions [38]. Thus, it acts as a static and dynamic model of the object represented with its help that in turn gives the chance to solve a rather wide range of tasks [39]. Petri Nets allow making a simulation in assembly lines [40, 41], to modeling and analysis of technological process [42-43], simulation of resources distribution at the enterprise [44-45].

It is offered to use estimated stochastic Petri Nets for model design in which tops of places have an integer of tags and are used for quantitative assessment by criteria of reliability and productivity for some parameters at systems functioning. In them, the probability of its operation per definite time is attributed to each transition [46].

This scheme (Fig.5) visually displays the formation sequence of the necessary database for grain delivery modeling. In parallel with the preparation of initial information, the choice and tuning are carried out for Petri Nets which will be used for studies process simulation.

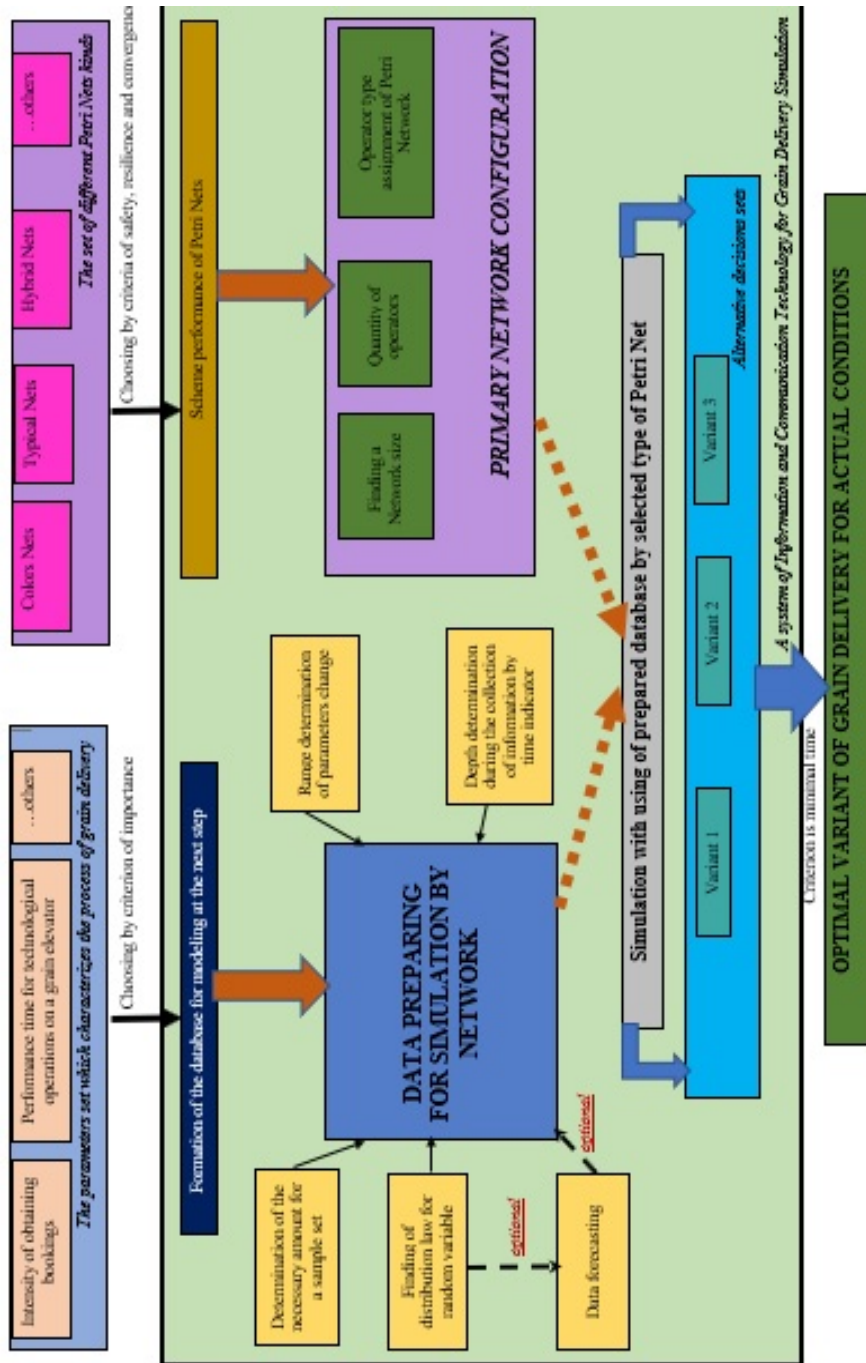

Fig. 5. View of information and communication technology system for grain delivery simulation

Considering functional communications between elements, it is possible to design the integrated model of Petri Net (Fig. 6), describing the functioning of the logistics system. This is a process of grain forwarding from the sender (farmer) to a seaport. The submitted scheme describes the process on the established elements: on transitions: T_1, T_2 – the receipt intensity of requests is defining from the trader and the farmer; T_3, T_5, T_6 – time of cargo shipping by trucks and railway wagons is defining; T_4, T_7, T_8, T_9 – distribution of cargoes, information, technical means is defined; by positions: P_1, P_2 – grain availability at the farmer and orders (technical means) at the trader is defined; $P_3 - P_{11}$ – the grain provision at each stage of operations performed is defined; $P_{12} - P_{14}$ – information availability on the performed work on each element is defined. The key places of the presented model are transitions T_4, T_7, T_8, T_9 and positions $P_{12} - P_{14}$ according to the previous thoughts. Therefore, maximum attention must be paid to these places during further modeling.

So main concentration of complex technological operations occurs on a model fragment $P_7 - P_9 - P_{10}$ for a logistical system of grain cargoes delivery [47].

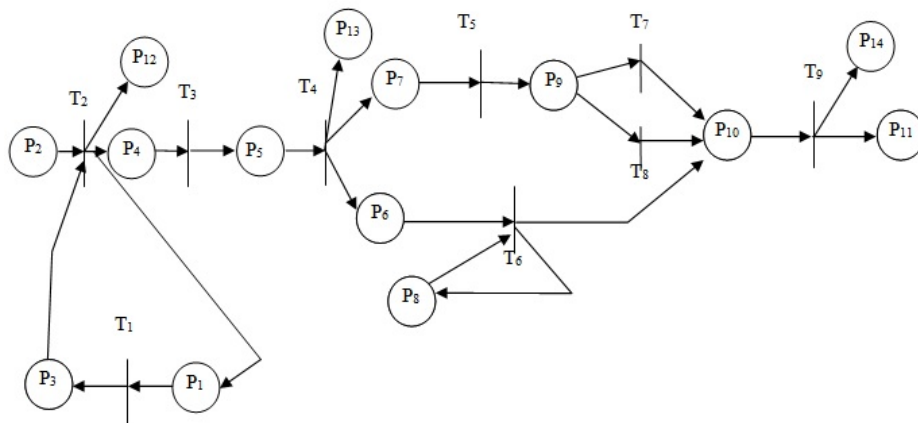

Fig. 6. The primary scheme of grain forwarding from the sender to the seaport

The designed macro-level model is universal for finding correct decisions of problems for this class (management of supply chains). At the same time adaptation of values for certain parameters is required, but the model structure does not change. Also, it is offered in this model to fix information on the performed work on each basic element. It is necessary for decision-making at the top information level. An expense of machine time is insignificant during simulation and its value makes up from two to ten seconds, depending on values of the influencing parameters (order volume). It allows making fast enough decisions when choosing the variant of the organization for cargo delivery in the logistical system.

It should be noted that the full-fledged model is quite bulky and therefore it is perceived hardly. This conditional scheme allows understanding the procedure of modeling considering formal representation of Petri Net which has the next view [38, 48]:

$$PN = \{P, T, F, W, M_0\}, \quad (3)$$

where P – final set of positions; T – final set of transitions; F – set of arcs (flow relations).

The expanded scheme of Petri Nets is provided for process visualization in the micro-level. This figure (Fig. 7) shows an example of a simulation procedure at the destination (cargo port railway station).

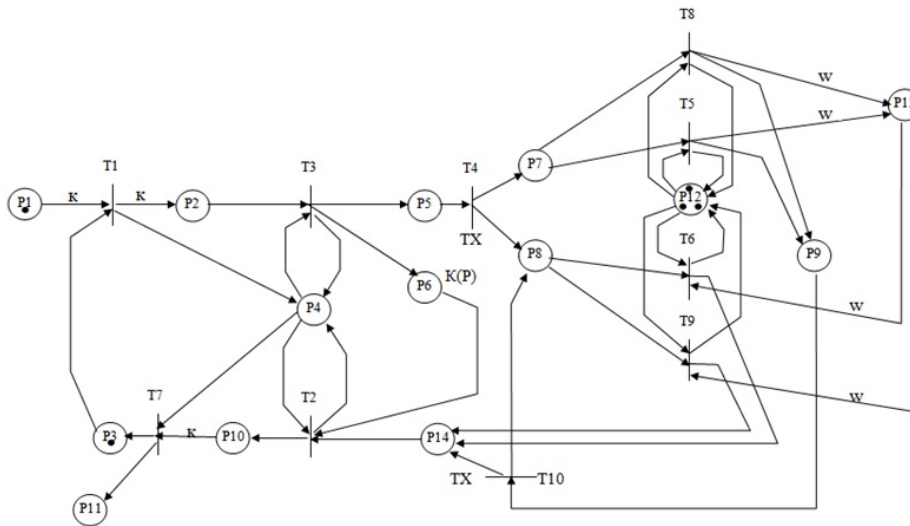

Fig. 7. The primary scheme which shows results of working by cargo-front of the port railway station

The designed networks were analyzed on safety, limitation, integrity, reliability. Assessment and analysis of complex systems by means of Petri Nets expediently to carry out by means of imitation modeling. It is confirmed also by the results of our experiment. At the same time, input flows of orders were set on the first step. They define the corresponding reaction of a system. Output parameters are calculated by means of statistical material processing which is accumulated during modeling.

4 Results and Discussion

Statistical analysis is carried out for parameters which were used for setting of initial values on transitions and positions at process modeling of logistical system operation during grain cargoes delivery.

T_i -indicators were divided into groups by characteristic criterion for statistical values assessment of used parameters which were set in transitions of model (Table.1) [49-51].

Table 1. Statistical assessment of model parameters

Name of parameters group	Volume of sampling	Diapason of parameter expected value	Distribution law
Intensity of obtaining bookings, units/hour	68	0.1-6	Exponential
Admission rate for grain from the field, t/hour	54	190-1200	Gamma-distribution
Performance time of technological operations on the motor transport, hour	28	0.3-4	Normal
Arrival intensity of trucks, unit/hour	58	1-12	Exponential
Performance time of technological operations on railway, hour	87	0.8-4	Normal
Arrival intensity of railway wagons, unit/hour	94	1-20	Exponential
Arrival intensity of railway locomotives, unit/hour	52	2.1-12.9	Exponential
Trains intensity of their arrival and departure, unit/hour	80	0.1-7.3	Exponential
Performance time of technological operations in port, hour	47	0.7-6.8	Normal
Performance time for technological operations on a grain elevator, hour	122	0.4-120	Exponential
Arrival intensity of sea ships to the port, unit/month	26	12-58	Exponential

The offered parameters set used in simulation for delivery time of grain at three alternative supply chains. At the same time, some random variables are distributed on other than the classical definition of distribution laws for these parameters. It can be explained by some formation features for this type of supply chain and forwarding specifics of grain cargoes turnover through them.

As a modeling result, data are obtained on the performance duration for main technological operations on all logistical system. Let's analyze the behavior of model depending on export order volumes of grain (Fig.8). The values amount of cargo turnover is defined proceeding from a confidence level, an error, and observations quantity. It has 68 units. At the same time, cargo turnover accepts values from 20 and to 3370 tons [52]. Three options distribution of cargo turnover are offered when using motor and railway transport: 1st variant – 100% of cargo to be transported by railway; the 2nd variant – equally on each type of transport; the 3rd supply chain – 100% of cargo is transported by the motor transport.

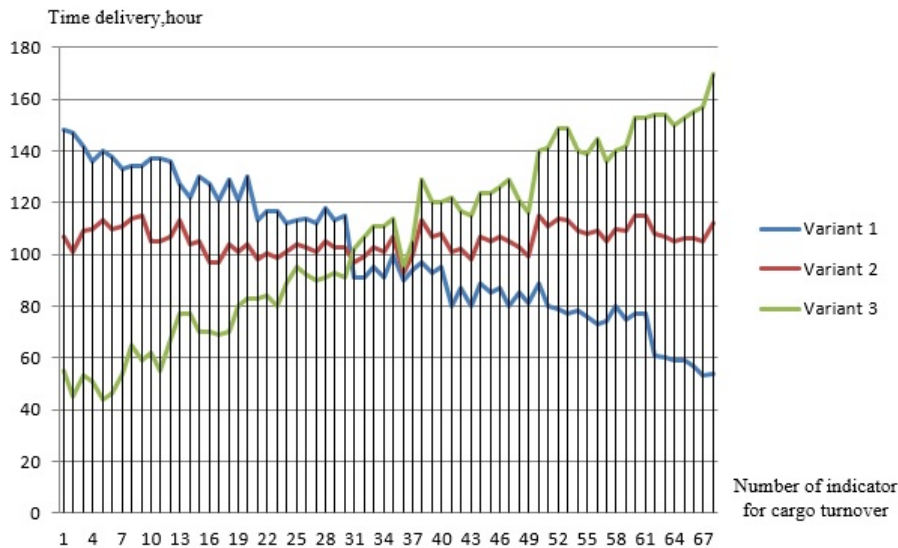

Fig. 8. Simulation results of grain cargoes delivery at logistical system by three variant of supply chains using Petri Net

Histogram (Fig. 8) allows making a fast decision on the best supply chain variant of grain cargoes from the sender to the recipient (port of departure). The choice is carried out by a criterion of the minimum delivery time. At the same time, the trend is accurately traced that to number 31 to which there corresponds cargo turnover near the 350th tons it will be favorable to use the motor transport. It is expedient to carry out delivery from a grain elevator to the port only by rail when volumes of sending grain will grow after 31st values. The alternative of trucks using is unacceptable in this case. It's explained by necessity to have a considerable quantity of trucks that are not favorable to the domestic agricultural enterprises.

It is visible according to the histogram (Fig. 8) that the average delivery time will have the second variant of the supply chain – a combination with two kinds of transport practically for all volumes of cargo turnover. This result of modeling completely shows the reality of the transport process in domestic conditions. The average time of forwarding cargo turnover is explained by the fact that motor transport is used on a small distance when the volumes of consignments are even considerable.

In this case, the application of Petri Net helps indirectly to define the necessary quantity of the rolling stock for delivery of the demanded grain volume to the port. The considered approach allows making the decision on scheme variant not only considering time but still not directly to estimate the possible costs connected with expenses per transportation. This type of expenses will depend in many respects from own carrying opportunities which enterprise has and from a percentage of leased vehicles.

Thus, application of simulation on the models developed by means of Petri Nets allows to track and analyze results at the first stage, and on the second step - to predict and to control a process for grain cargoes forwarding at the logistic system.

5 Conclusion

The successful example of Petri Nets use was shown in research in the form of ICT system for logistic problems decision. This modeling instrument allows fast receiving values of time about grain forwarding through a supply chain. It considerably will facilitate the primary choice of a supply chain.

The analysis of the theoretical basis of Petri Nets is made and its adequacy of their application for transport processes modeling is proved. It is shown that Petri Nets allow to investigate more deeply behavior of the modeled system and to obtain information on its most important characteristics. They also take into accounting that logistical systems of grain delivery must be considered as the systems of parallel information processing and in parallel operating of objects. Therefore, the offered approach is universal for the problems' decision of a similar class.

An advantage of Petri Nets application consists of small labor input when developing and an opportunity to correctly simulate process at a small amount of initial information.

The developed visual scheme for the system of information and communication technologies when modeling options of transportation of grain cargo-turnover based on Petri Nets. It allows unifying staging of the choice for a type of mathematical tools and in parallel to format the initial database.

That's why using of such ICT considerably will accelerate the adoption for correct decision on the choice of a supply chain that minimizes expenses of the logistic companies when exporting the Ukrainian grain.

References

1. Wang, F., Xu, Z., Zhen, T., Zhang, X., Zhang, M.: Grain Logistics Management Information System Based on Short Message Service Technology. *Mechatronics and Automatic Control Systems. Lecture Notes in Electrical Engineering*. vol. 237. Springer, Cham. (2014). doi: 10.1007/978-3-319-01273-5_62
2. Shramenko, N.Y., Shramenko, V.O.: Mathematical model of the logistics chain for the delivery of bulk cargo by rail transport, *Scientific Bulletin of National Mining University*, Vol. 5, No. 167, 136-141 (2018). doi: 10.29202/nvngu/2018-5/15
3. Cao, R., Hao, L., Wang, F., Gao, Q.: Modelling and analysis of hybrid stochastic timed Petri net, *Journal of Control and Decision*. Vol. 6:2, 90-110. (2019) doi: 10.1080/23307706.2017.1419079
4. Peraković, D., Periša, M., Sente, R.E.: Information and Communication Technologies Within Industry 4.0 Concept. *Advances in Design, Simulation and Manufacturing. DSMIE. Lecture Notes in Mechanical Engineering*, pp. 127-134, Springer, Cham (2018) doi: 10.1007/978-3-319-93587-4_14
5. Fernando, E., Surjandy, Harco Leslie Hendric Spits Warnars, Meyliana, Kosala, R.; Abdurachman, E.: Critical Success Factor of Information Technology Implementation in Supply Chain Management: Literature Review 5th International Conference on Information Technology, Computer, and Electrical Engineering (ICITACEE). IEEE. (2018) doi: 10.1109/ICITACEE.2018.8576979

6. Zelikov, V.A., Akopova, E.S., Pilivanova, E.K., Popova, L.K.: Model of Management of the Risk Component of Intermodal Transport: Information and Communication Technologies of Transport Logistics. Perspectives on the Use of New Information and Communication Technology (ICT) in the Modern Economy. ISC 2017. Advances in Intelligent Systems and Computing. Vol. 726. Springer, Cham. (2019). doi: 10.1007/978-3-319-90835-9_77
7. Shramenko, N.Y.: Methodology for evaluation of synergy effect in terminal cargo delivery system. Actual Problems of Economics, Vol. 8, No. 182, 439-444 (2016)
8. Ukrainian Grain Exports, <http://minagro.gov.ua/>, last accessed 2019/02/19
9. Muzylyov, D.A., Kravcov, A.G., Karnayh, N.V., Berezhnaja, N.G. & Kutiya, O.V.: Development of a Methodology for Choosing Conditions of Interaction Between Harvesting and Transport Complexes. Eastern European Journal of Enterprise Technologies, Vol. 2, No.3, 11-21 (2016). doi: 10.15587/1729-4061.2016.65670.8.
10. Shramenko, N.Y.: Effect of process-dependent parameters of the handling-and-storage facility operation on the cargo handling cost. Eastern European Journal of Enterprise Technologies, Vol. 5/3, No. 77, 43-47 (2015). doi: 10.15587/1729-4061.2015.51396.
11. Shramenko, N. Y.: The methodological aspect of the study feasibility of intermodal technology of cargo delivery in international traffic. Scientific Bulletin of National Mining University, Vol. 4, No. 160, 145-150 (2017).
12. Ukrainian Ports Turnover in 2018: Main Trends, ports.com.ua/articles/gruzooborot-portov-ukrainy-2018-glavnye-trendy, last accessed 2019/03/21
13. Shramenko, N., Muzylyov, D., Karnaukh, M.: The Principles of the Choice of Management Decisions Based on Fuzzy Logic for Cargo Delivery of Grain to the Seaport. International Journal of Engineering & Technology, Vol. 7, No. 4.3, 211-216 (2018). <https://doi.org/10.14419/ijet.v7i4.3.19789>.
14. Kirichenko, A.I. The Application of Information Technologies in the Management of Cargo Delivery Processes. Transport Problems: Collection of Scientific Papers, Vol. 9, NTU, 17-27 (2012).
15. Velykodnyi, D., Pavlenko, O.: The choice of rational technology of delivery of grain cargoes in the containers in the international traffic. International journal for traffic and transport engineering. Vol. 7, No. 2, 164-175 (2017). doi: 10.7708/ijtte.2017.7(2).02
16. Shramenko, N. Y.: Evaluation of the effectiveness of piggyback traffic in the context of creating transport and logistics clusters. Scientific Bulletin of National Mining University, Vol. 6, No. 162, 151-155 (2017)
17. Xu, X.Q.: Research on Applied Technology with Development of Modern Computer Simulation Technology, Advanced Materials Research. Vol. 908, 563-566 (2014). doi: 10.4028/www.scientific.net/AMR.908.563
18. Konovalenko, I., Ludwig, A.: Event processing in supply chain management – The status quo and research outlook. Computers in Industry. Vol. 105, 229-249 (2019). doi: 10.1016/j.compind.2018.12.009
19. Abed, M., Charfeddine, I., Benaissa, M., Starostka-Patyk, M.: Intelligent Traceability System of Containerized Goods, Applied Mechanics and Materials. Vol. 309, 241-251 (2013). doi: 10.4028/www.scientific.net/AMM.309.241
20. Li, F., Zhu, Y.P., Wu, H.R.: Modeling and Optimization of Traceability System for Agriculture Products Supply Chain, Advanced Materials Research. Vols. 605-607, 574-579 (2013). doi: 10.4028/www.scientific.net/AMR.605-607.574
21. Qu, J.H., Yao, X. S., Ying, J.L.: Agricultural Products Logistics Operational Pattern Based on Information Center, Advanced Materials Research. Vols. 361-363, 1679-1683, (2012) doi: 10.4028/www.scientific.net/AMR.361-363.1679

22. Vendrell-Herrero, F., Bustinza, O. F., Parry, G., Georgantzis, N.: Servitization, digitization and supply chain interdependency. *Ind. Mark. Manag.* Vol. 60, 69-81 (2017). doi: 10.1016/j.indmarman.2016.06.013
23. Xue, L., Zhang, C., Ling, H., Zhao X.: Risk mitigation in supply chain digitization: system modularity and information technology governance. *J. Manag. Inf. Syst.* Vol. 30, 325-352 (2013). doi: 10.2753/MIS0742-1222300110
24. Aulin, V., Lyashuk, O., Pavlenko, O., Velykodnyi, D., Hrynkiv, A., Lysenko, S., Holub, D., Vovk, Y., Dzyura, V., Sokol, M.: Realization of logistic approach in the international cargo delivery system. *Communications - Scientific Letters of the University of Zilina.* Vol. 21(2), 5-14, (2019).
25. Jin, C.F., Yang, H.M., Ling, L.: Research on Optimization and Debugging Simulation Model of Logistics Center Based on Neural Network, *Applied Mechanics and Materials.* Vols. 37-38, 1060-1063 (2010). doi: 10.4028/www.scientific.net/AMM.37-38.1060
26. He, W., Lu, T., Yu, C.Q.: A Novel Traffic Flow Forecasting Method Based on the Artificial Neural Networks and Intelligent Transportation Systems Data Mining, *Advanced Materials Research.* Vol. 842, 708-711 (2014). doi: 10.4028/www.scientific.net/AMR.842.708
27. Subbotin, S.O., Oliynyk A.O.: *Neural Networks: Teach. manual.* Zaporizhzhya, ZNTU (2014).
28. Wang, L., Zhu, X.N., Xie, Z.Y.: Object-Oriented Petri Net Modeling and Analysis of China Railway Container Freight Yard Logistic System, *Key Engineering Materials.* Vols. 467-469, 990-995 (2011). doi: 10.4028/www.scientific.net/KEM.467-469.990
29. Zhong, W.Z., Fu, X.Q., Wang, Y.P.: Petri Net Modeling: Container Terminal Production Operation Processing System Analysis, *Applied Mechanics and Materials.* Vols. 409-410, 1320-1324 (2013). doi: 10.4028/www.scientific.net/AMM.409-410.1320
30. Zhang, G.X., He, S., Zhang, Z.Y.: Study on Model Validation of Logistics System Based on Petri Nets, *Applied Mechanics and Materials.* Vols. 195-196, 853-858 (2012). doi: 10.4028/www.scientific.net/AMM.195-196.853
31. Gaied, M., M'halla, A., Lefebvre D.: Robust control for railway transport networks based on stochastic P-timed Petri net models, *Proceedings of the Institution of Mechanical Engineers, Part I: Journal of Systems and Control Engineering,* (2019). doi: 10.1177/0959651818823583
32. Zhong, W.Z., Fu, X.Q., Wang, Y.P.: LOPN-Based BPR of Container Terminal Production Controlling System, *Applied Mechanics and Materials.* Vol. 367, 441-446 (2013). doi: 10.4028/www.scientific.net/AMM.367.441
33. Perdana, Y.R.: Logistics Information System for Supply Chain of Agricultural Commodity *Procedia - Social and Behavioral Sciences.* Vol. 65(3), 608-613 (2012). doi: 10.1016/j.sbspro.2012.11.172
34. Trzuskawska-Grzesińska, A.: Control towers in supply chain management – past and future, *Journal of Economics & Management.* Vol. 27, 114-133 (2017). doi: 10.22367/jem.2017.27.07
35. Marinagi, C., Skourlas, C., Galiotou, E.: Advanced information technology solutions for implementing information sharing across supply chains. In: *22nd Pan-Hellenic Conference on Informatics*, pp. 99-102 (2018). doi: 10.1145/3291533.3291575
36. Borgi, T., Zoghlami, N., Abed, M., Saber Naceur, M.: Big Data for Operational Efficiency of Transport and Logistics: A Review. In: *6th IEEE International Conference on Advanced Logistics and Transport (ICALT)* (2017). doi: 10.1109/ICAdLT.2017.8547029

37. Yaqiong, L.V., Lei, T.U., Lee, C.K.M, Xin, T.: IoT based Omni-Channel Logistics Service in Industry 4.0. In: International Conference on Service Operations and Logistics, and Informatics (SOLI). IEEE. pp. 240-243 (2018). <https://doi.org/10.1109/SOLI.2018.8476708>
38. Chinnusamy, T.R., Karthikeyan, T., Krishnan, M., Murugesan, A.: A Comprehensive Survey of Flexible Manufacturing System Scheduling Using Petri Nets, *Advanced Materials Research*. Vols. 984-985, 111-117 (2014). doi: 10.4028/www.scientific.net/AMR.984-985.111
39. Zhang, Y.H., Zhang, X.F.: Modeling and Simulation Method of Component Based Petri Net, *Advanced Materials Research*. Vol. 936, 2254-2258 (2014). doi: 10.4028/www.scientific.net/AMR.936.2254
40. Dong, H., Xin, H.B., Yan J.H.: Modeling in Mixed-Model Assembly Lines Based on Object-Oriented Petri Net, *Advanced Materials Research*. Vols. 945-949, 3156-3159 (2014). doi: 10.4028/www.scientific.net/AMR.945-949.3156
41. Tian, S.L., Tian, Y., Xiao, X. H., Chen, D.X., Wang, T.Y., Zhang, L.: Defining Method Research of Technological Conflict Based on Petri Net Theory, *Key Engineering Materials*. Vol. 693, 2016-2021 (2016). doi: 10.4028/www.scientific.net/KEM.693.2016
42. Culea, G., Cristea, I., Puiu, P.G.: Modeling and Analysis of Processing Flow in a Flexible Manufacturing System Using Synchronized Petri Nets, *Applied Mechanics and Materials*. Vols. 809-810, 1474-1479 (2015). doi: 10.4028/www.scientific.net/AMM.809-810.1474
43. Prayoga, P.H.N., Shinoda, T.: A Petri Net Model and its Simulation for Straddle Carrier Direct-System Operation in a Container Terminal, *Applied Mechanics and Materials*. Vol. 862, 202-207 (2017). doi: 10.4028/www.scientific.net/AMM.862.202
44. Klosowski, G., Gola, A., Świć, A.: Human Resource Selection for Manufacturing System Using Petri Nets, *Applied Mechanics and Materials*. Vol. 791, 132-140 (2015). doi: 10.4028/www.scientific.net/AMM.791.132
45. Liu, B.W.: A New Deadlock Avoidance Policy Based on Petri Nets in Distributed System, *Applied Mechanics and Materials*. Vol. 743, 575-580 (2015). doi: 10.4028/www.scientific.net/AMM.743.575
46. Prostitenko, O.V., Khalimon, V.I., Rogov, A.Y.: Simulation of discrete systems based on Petri nets: study guide. St. Petersburg, SPbGTI (TU) (2017).
47. Lomot'ko, D.V. Arsenenko, D.V.: Creation of an effective technology for the formation of railway tracks with grain cargoes using models on the Petri network. *Information management system on the railway transport*. Vol. 6, 38-45 (2018). doi: 10.18664/iksz.voi6.151642
48. Appel, M., Konigorski, U., Walther M.: A Graph Metric for Model Predictive Control of Petri Nets. *Science Direct, IFAC Papers On-Line* 51-2. pp. 254–265 (2018). doi: 10.1016/j.ifacol.2018.03.044
49. Naumov, V.S.: Forwarding services in logistics systems: Monograph / 2nd ed. – Kharkov, HNADU (2014).
50. Murad'yan, A.O.: Coordinated management of the process of handling of goods in the gantry hubs: monograph. Odessa, Kuprienko S.V. (2017).
51. The unified technological process of the work of the State Enterprise “Odessa Commercial Sea Port” and the Odessa-Port Port of the Odessa Railway, <http://www.port.odessa.ua>, last accessed 2019/03/14
52. Kernel-Trade Company Presentation, https://www.kernel.ua/wp-content/uploads/2019/02/Kernel_FY2019_H1_Presentation.pdf, last accessed 2019/03/29