

Rec'd. 1-25-63

# Erecting Instructions *Series* TYPE D GAS Weil-McLain Boiler

Also see MC-1185

## GENERAL INSTRUCTIONS

Locate the boiler as close as possible to the chimney, taking care to provide ample clearance for access to the piping. It is required that a clearance of 24" be allowed at sides where servicing will occur and 18" allowed at a side where passage is necessary to another side requiring servicing or cleaning. Clearance on remaining sides should be no less than 6". See Page 4 for permissible minimum clearance for alcove installations.

**NOTE:** Installations must conform with the requirements of local utilities and those of other local authorities having jurisdiction.

## CHIMNEY OR FLUE

The masonry chimney or Type A flue to which the boiler is connected must have a cross-sectional area not less than that of the cross-sectional area of the draft hood. The chimney should extend at least two feet above the highest part of the roof so that wind from any direction will not strike the flue or vent from an angle above horizontal and not produce a positive static pressure. Chimney linings should be used when required by national, state or local building codes. Vitreous tile linings with joints which prevent retention of moisture and linings made of non-corrosive materials are advantageous. Advice regarding recommended practice and material for flue connections and chimney linings can usually be obtained from the local gas company and should be given careful consideration. In the event a Type B or Type C vent is used, the instructions relative to size and height contained in the Manual ASA Z21.30-1959, American Standard Installation of Gas Appliances and Gas Piping should be followed. The chimney should be examined before the gas boiler is installed to ascertain that it is properly constructed, clear, and will freely conduct the products of combustion to the outer air. Flue piping should not extend beyond the inside wall of the chimney. Do not place a damper or any other obstruction in the flue pipe. The flue pipe should slope up toward the chimney at least 1/4" per foot and must be the same size as the outlet of the draft diverter. Where two or more appliances vent into a common flue, the area of the common flue should be at least equal to the area of the largest flue or vent connector plus 50% of the area of the additional flue or vent connector.

## AIR SUPPLY FOR BOILER ROOM

Provisions must be made to supply sufficient air to the boiler room at all times. In buildings of conventional frame, brick, or stone construction without enclosed utility rooms, basement storm windows, or tight stair doors, infiltration is normally adequate to provide air for combustion and draft-hood dilution. For installations in utility rooms without an outside wall, ventilation to the rooms should be provided by placing an opening at the top and bottom of the room allowing a minimum of 1 square inch of opening for each 1000 BTU per hour input with not less than a 100 square inch opening in each location.

Where openings to interior spaces are impracticable, openings to the outside with a minimum free area of 1 square inch per 4000 BTU per hour of input rating should be provided.

## IMPORTANT PRECAUTIONS

Proper installation and adjustment of burners and control equipment are important for the successful operation of the gas boiler. The operating instruction plate furnished with the boiler is mounted on the inner jacket panel. Read the instructions very carefully before starting the gas boiler.

## BOILER FOUNDATION

A level concrete or brick foundation is strongly recommended and should be from two to a maximum of six inches above floor level if head-room permits.

### MINIMUM FOUNDATION DIMENSIONS

Boiler No.	Length (L) Inches	Boiler No.	Length (L) Inches
D-3	12	D-7	22
D-4	14	D-8	24
D-5	17	D-9	27
D-6	19	D-10	29

These dimensions allow about 1 inch clearance all around the boiler.

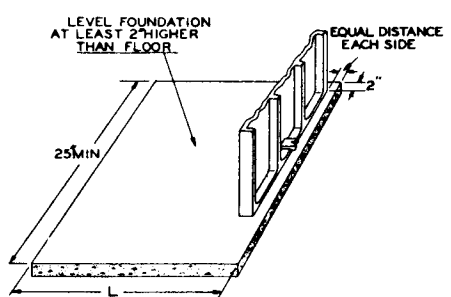
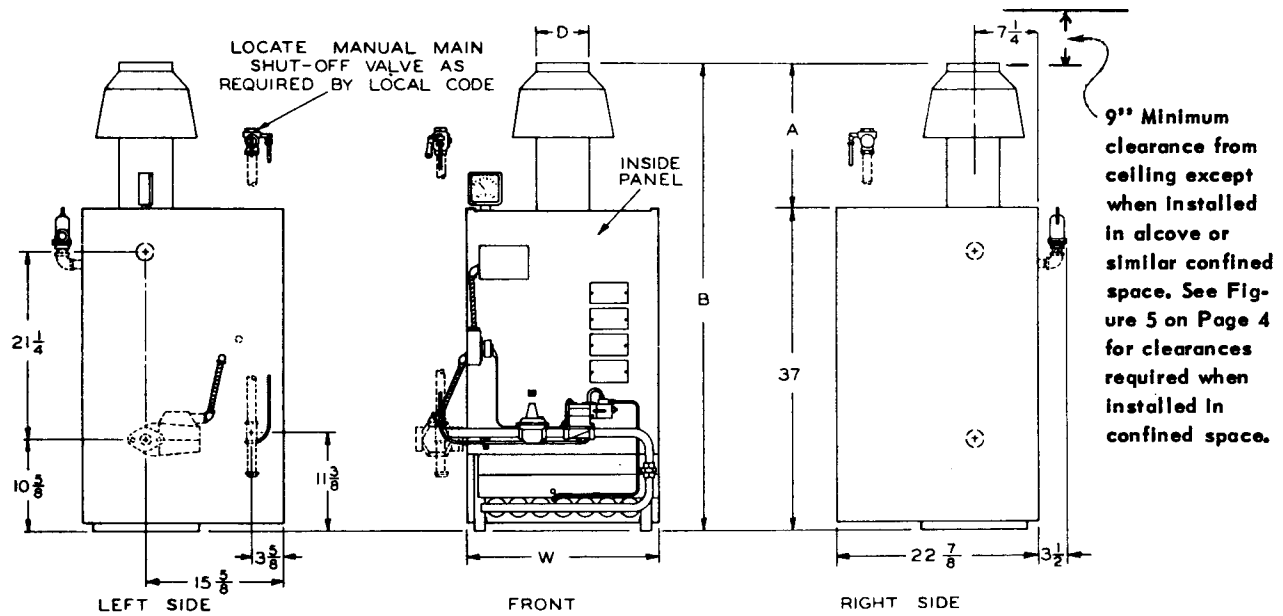

Figure 1



Dotted Items Not Supplied

Figure 2

NOTE: Gas regulator must be installed outside of jacket housing on D-3 boiler.

## DIMENSIONS

Boiler Size		D-3	D-4	D-5	D-6	D-7	D-8	D-9	D-10
Tappings No. and Size	Supply	1-1/4"	1-1/4"	1-1/4"	1-1/4"	1-1/4"	1-1/4"	1-1/4"	1-1/4"
	Return	1-1/4"	1-1/4"	1-1/4"	1-1/4"	1-1/4"	1-1/4"	1-1/4"	1-1/4"
Mfd. Gas Pipe Size ●		1/2"	1/2"	1/2"	1/2"	3/4"	3/4"	3/4"	1"
Mixed Gas Pipe Size ●		1/2"	1/2"	1/2"	1/2"	1/2"	1/2"	3/4"	3/4"
Natural Gas Pipe Size ●		1/2"	1/2"	1/2"	1/2"	1/2"	1/2"	3/4"	3/4"
Propane Gas Pipe Size ●		1/2"	1/2"	1/2"	1/2"	1/2"	1/2"	3/4"	3/4"
Dimension A		11-5/8"	11-5/8"	14"	14"	16-1/8"	16-1/8"	19"	19"
Dimension B		48-5/8"	48-5/8"	51"	51"	53-1/8"	53-1/8"	56"	56"
Dimension D		4"	4"	5"	5"	6"	6"	7"	7"
Dimension W		9-1/4"	11-3/4"	14-1/4"	16-3/4"	19-1/4"	21-3/4"	24-1/4"	26-3/4"

● Sizes shown are control sizes. Hand valves may be smaller.

## RATINGS AND DATA

Boiler No.	A.G.A. Input BTU Per Hour	A.G.A. Gross Output BTU Per Hour	Net I-B-R Ratings * BTU Per Hour	Net Ratings Sq. Ft. @ 150 BTU Emission Per Sq. Ft.	Minimum A.S.M.E. Relief Valve Capacity BTU Per Hour	Flue ** Dia. Inches
D-3	45,000	36,000	27,000	180	36,000	4
D-4	67,500	54,000	40,500	270	54,000	4
D-5	90,000	72,000	54,000	360	72,000	5
D-6	112,500	90,000	67,500	450	90,000	5
D-7	135,000	108,000	81,000	540	108,000	6
D-8	157,500	126,000	94,500	630	126,000	6
D-9	180,000	144,000	108,000	720	144,000	7
D-10	202,500	162,000	121,500	810	162,000	7

\* Net I-B-R ratings are based on net installed radiation of sufficient quantity for the requirements of the building and nothing need be added for normal piping and pick up. Exception: An additional allowance should be made for unusual piping and pick up loads.

\*\* Chimney heights should be 20 feet. In special cases where surrounding conditions permit, chimney height may be reduced to 10 feet.

**ERECTING SECTIONS**

1. Position the section assembly on its foundation centered from left to right on the foundation and within 2" (measuring from the legs of the section assembly) of the rear of the foundation. The supply and return may be piped on either side by turning the section assembly with the tapping end in the direction for most convenient piping. Figure 3 below shows section assembly for L.H. supply and return. See tapping arrangement Charts and Figures 6 and 7, Page 5. (For combustible floor and close clearance, see Page 4.)

2. Place a generous amount of boiler cement all around the inside of the ridge on top of the assembled sections. Center the collector hood from left to right in the recess space provided on top of the section assembly. Secure the collector hood with the 5/16" x 5/8" bolts provided. Insert the square nut under the cast holding lugs and pass the bolt down through the collector hood tabs and turn down tight securing each end of the collector hood firmly to the section assembly. See Figure 3.

Seal any cracks with additional boiler cement between the hood and sections. Wipe the joints smooth. See detail drawing in Figure 3.

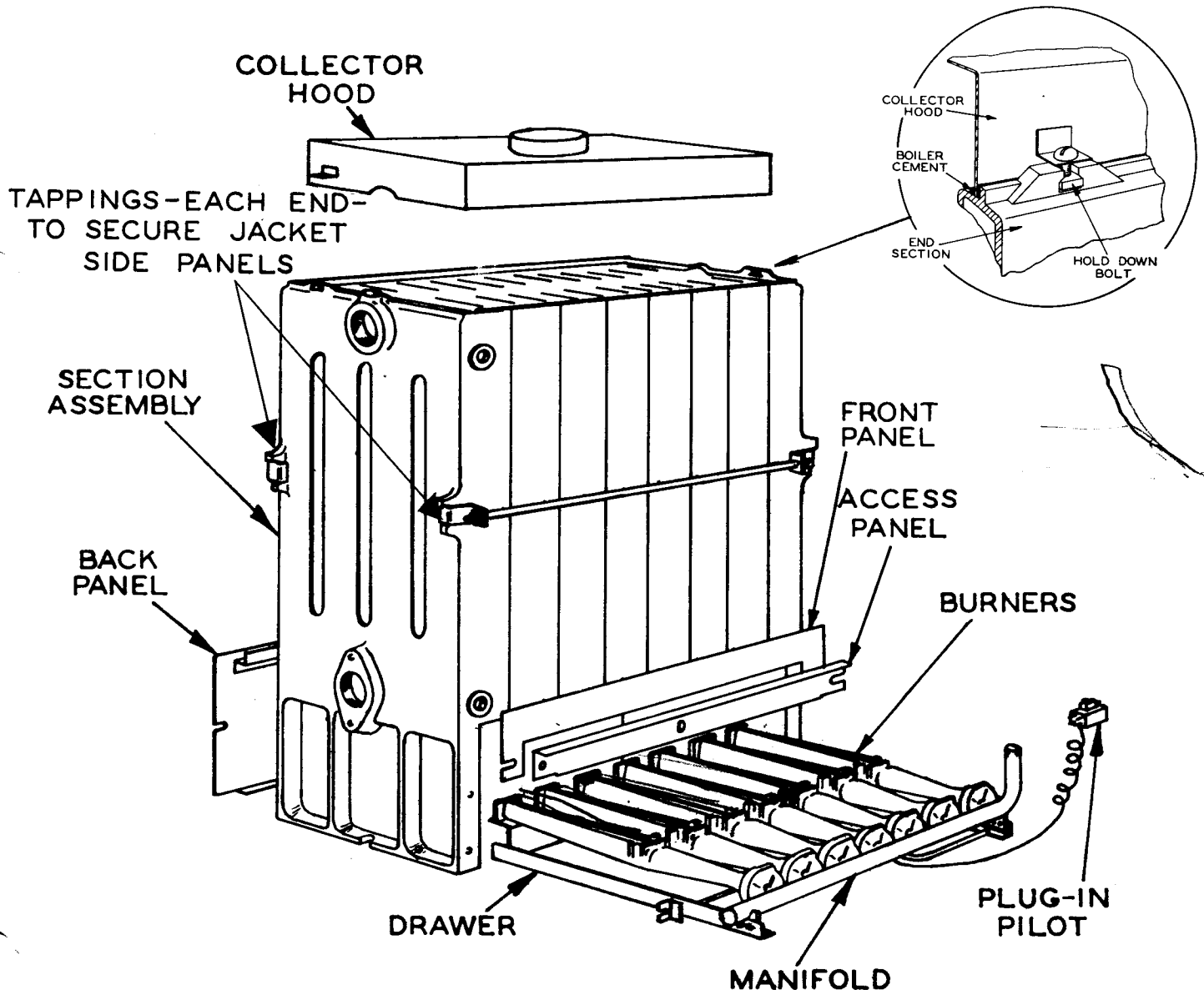

Figure 3

## COMBUSTIBLE FLOOR

- If the boiler is to be erected on a combustible floor our heat shield Part No. D-P26-A must be placed under the legs of the boiler base and on the floor to comply with A.G.A. approval. See Figure 4.

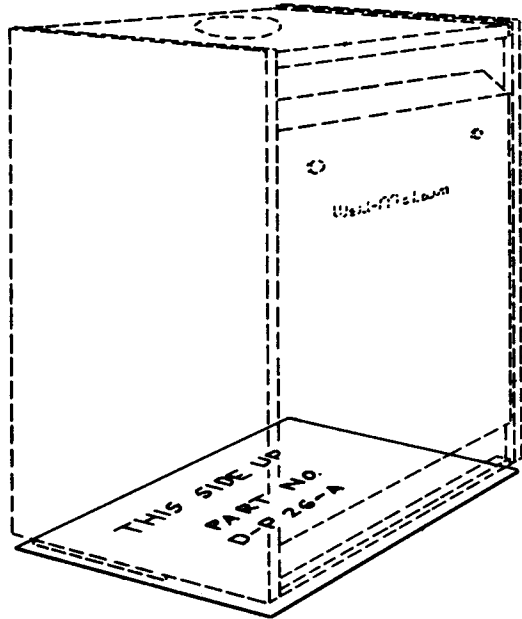

Figure 4

## CLOSE CLEARANCE

- If the boiler is to be located in a confined space, clearance should be provided on all sides as shown in Figure 5 for alcove installation. The flue pipe must not be closer than 6" from combustible material.

MINIMUM CLEARANCE FOR ALCOVE INSTALLATION

\* Note: See Figure 2 on Page 2 for minimum ceiling clearance, when installed in larger rooms.

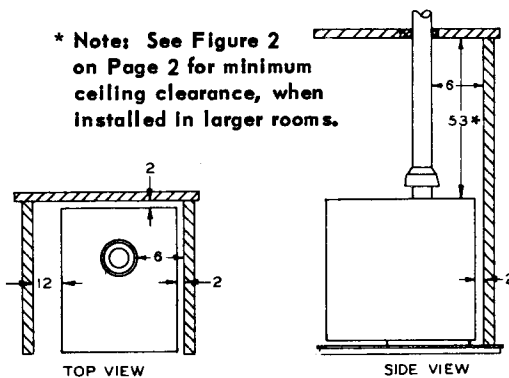

APPROVED FOR INSTALLATION ON COMBUSTIBLE FLOORING WHEN PART D-P26-A IS INSTALLED UNDER THE ENTIRE BOILER.

Figure 5

- Inspect the boiler for leakage. Plug all tapings, using the high limit circulator control

well, if necessary, to plug the high limit control tapping. Fill boiler with water and test with water pressure not exceeding forty-five (45) pounds. Inspect boiler carefully to insure against leaks and damage from handling and shipping.

- Drain boiler and remove plugs where tapings are to be used. See tapping arrangement chart for identification. (See Page 5.)
- If a drain cock is to be installed on the boiler as we recommend, it may be installed in tapping D in the front or rear of boiler. However, if it is installed in the front it may be installed at this time. If it is to be installed in the rear it must be installed after the jacket is erected. Drain cock not supplied.

## WATER TRIM

- Screw the 1/2 x 2 1/2" nipple and the 1/2" coupling into tapping E.
- Screw the combination pressure, temperature and altitude gauge (tridicator) into the coupling making sure that the tridicator faces either the front or side of the boiler.

## DRAWER ASSEMBLY MANIFOLD AND BURNERS

- Remove drawer assembly from shipping crate, checking to make sure all burners are positioned in holes in burner support bracket with spuds inserted in opening in mixing tube.
- Facing the side of the boiler which has been selected as the front, slide drawer assembly into position so that it fits between lugs provided on inner side of the end sections. See Figure 3.
  - The positioning and holding bracket should be against the legs of the end sections when drawer is in position.
  - Secure the drawer assembly to the end sections with the two 1/4" x 3/8" R.H. screws provided.
  - The drawer assembly may be removed without removing the two 1/4" x 3/8" R.H. screws. To do this loosen the two screws and raise the drawer assembly until the ears on the drawer assembly bracket clear the round head screws and pull out.

(Cont. on Page 6)

**TAPPING ARRANGEMENT CHART**

**For Left Hand Supply and Return Piping Arrangement**

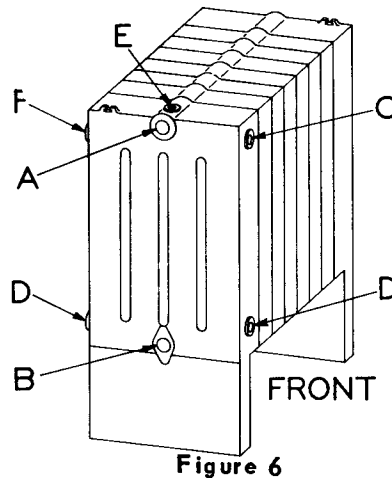

Figure 6

**TABLE 1  
TAPPING ARRANGEMENT**

Location	Number	Size	Use For Forced Hot Water
A	1	1/4	Supply
B	1	1/4	Return
C	1	3/4	Limit Circulator Control
D	2	3/4	Drain Cock
E	1	1/2	Tridicator
F	1	3/4	Relief Valve

**For Right Hand Supply and Return Piping Arrangement**

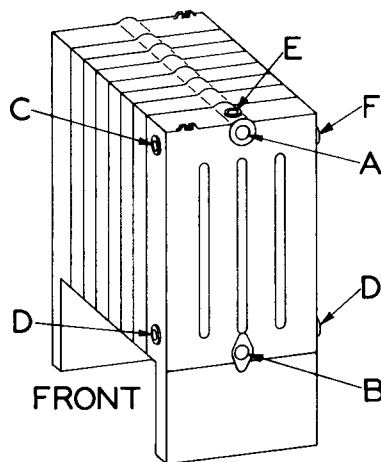

Figure 7

3. Before installing the front panel, place a generous amount of boiler cement in the U groove of the panel. Install the front panel with the U-slot up, hooking its top under the edge of the intermediate section and holding it in place with the two 1/4" x 1/2" slotted hex. head brass screws. Do not tighten these screws, since the access panel will be held in place with the same screw. Install the front access panel with the slot to the right and the round hole to the left with the wording out. Slide the slot over the hex. screw and hooking the round hole over the left hex. screw. Secure both front panel and access panel in place with the two hex. screws. Note the hex. screws do not have to be removed to remove the access panel. They only have to be loosened to remove this panel.
  - a. Pilot observation hole in the access panel should line up with pilot. See Table 2.
4. Before installing the rear panel, place a generous amount of boiler cement in the U groove of the panel. Install the rear panel with the U-slot up, hooking its top under the edge of the intermediate section and securing it with the two 1/4" x 1/2" slotted hex. head brass screws.

TABLE 2

NUMBER OF BURNERS WITH PILOT LOCATIONS	
BOILER NUMBER	PILOT LOCATION
D-3	<input type="checkbox"/> P <input checked="" type="checkbox"/>
D-4	<input type="checkbox"/> P <input checked="" type="checkbox"/> <input type="checkbox"/>
D-5	<input type="checkbox"/> <input type="checkbox"/> P <input checked="" type="checkbox"/> <input type="checkbox"/>
D-6	<input type="checkbox"/> <input type="checkbox"/> P <input checked="" type="checkbox"/> <input type="checkbox"/> <input type="checkbox"/>
D-7	<input type="checkbox"/> <input type="checkbox"/> <input type="checkbox"/> P <input checked="" type="checkbox"/> <input type="checkbox"/> <input type="checkbox"/>
D-8	<input type="checkbox"/> <input type="checkbox"/> <input type="checkbox"/> P <input checked="" type="checkbox"/> <input type="checkbox"/> <input type="checkbox"/> <input type="checkbox"/>
D-9	<input type="checkbox"/> <input type="checkbox"/> <input type="checkbox"/> <input type="checkbox"/> P <input checked="" type="checkbox"/> <input type="checkbox"/> <input type="checkbox"/> <input type="checkbox"/>
D-10	<input type="checkbox"/> <input type="checkbox"/> <input type="checkbox"/> <input type="checkbox"/> <input type="checkbox"/> P <input checked="" type="checkbox"/> <input type="checkbox"/> <input type="checkbox"/> <input type="checkbox"/> <input type="checkbox"/>
<input type="checkbox"/>	BURNERS
P	PILOTS
<input checked="" type="checkbox"/>	BURNERS WITH PILOT

JACKET ASSEMBLY

Caution: Proper Knockouts must be removed from the jacket panels (before assembling the jacket) to provide access to boiler tappings that will be

used. This is determined by whether left hand arrangement per Figure 6 or right hand arrangement per Figure 7 is selected.

Follow the instructions packed in the jacket carton giving directions for the complete assembly of the jacket. Be sure to install A.G.A. plate and other plates as directed in jacket erecting instructions.

Parts to be attached before Jacket is erected.

- Collector Hood
- Rear Panel
- Drawer Assembly
- Required Plugs
- High Limit Circulator Control Well

Parts to be attached after Jacket is erected.

- Relief Valve\*
- High Limit Circulator Control
- Wiring Harness
- Gas Control Assembly +
- Draft Hood
- Piping To System

\* Install the relief valve in the tapping indicated on Page 5. (Note: The nipple and elbow to attach the relief valve are not supplied.)

+ The gas controls for the "D" gas boiler are shipped assembled except the D-3. The D-3 will have the pressure regulator located outside the jacket.

DRAFT HOOD

1. Install the draft hood to the outlet of the collector hood at the top of the jacket. The draft hood must be installed as it is received without any alterations.

CONNECTING THE GAS CONTROLS OF WHITE-RODGERS 24 V SYSTEM

The gas controls for the type D gas boiler are shipped assembled.

1. Connect the control assembly to the manifold by means of the union. See Figure 9.

2. Plug in the automatic pilot to the main gas valve.

Caution: Care should be taken to prevent kinks when making bends in the capillary lead.

3. Connect the outlet side of the automatic plug-in pilot valve to the tubing marked "pilot tubing" below the manifold.

4. Connect the gas line to the meter. The manual main shut-off valve should be installed in accordance with local utility company requirements. A trap must be installed at the inlet of the gas connection to the unit to satisfy A.G.A. requirements.

5. Connect the pilot tubing from the pilotcock to the inlet of the plug-in automatic pilot (100% shut-off).
6. Check all gas connections for leaks -- use a soapy solution -- do not use a flame. Liability for damage done through the use of a flame when testing for gas leaks cannot be assumed by the manufacturer.

### CONNECTING THE GAS CONTROLS OF M-H 24V SYSTEM

1. Connect the control assembly to the manifold by means of the union. See Figure 11.
2. Connect the loose end of the thermocouple lead to the top of the main gas valve and turn nut with fingers until thermocouple is firmly seated. Do not tighten more than 1/4 turn beyond finger tight.

**Caution:** Care should be exercised in bending the thermocouple lead when making connection to the main gas valve. Bend should not be made within one inch from either end.

3. Connect the outlet side of the 100% shut-off pilotstat to the tubing marked "pilot tubing" below the manifold.
4. Connect the gas line to the meter. The manual main shut-off valve should be installed in accordance with local utility company requirements. A trap must be installed at the inlet of the gas connection to the unit to satisfy A.G.A. requirements.
5. Connect the pilot tubing from the pilot cock to the inlet side of the 100% shut-off pilotstat.
6. Check all gas connections for leaks. Use a soapy solution -- do not use a flame. Liability for damage done through the use of a flame when testing for gas leaks cannot be assumed by the manufacturer.

#### WHITE RODGERS PILOT AND CONTROLS

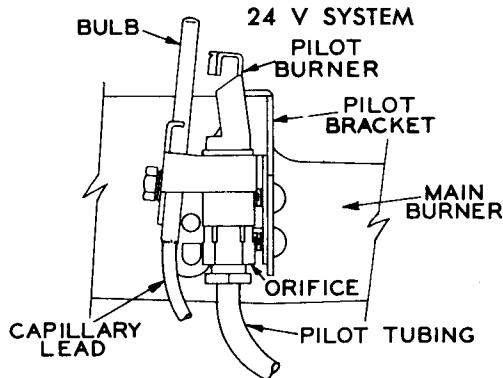

WHITE RODGERS LIQUID FILLED PILOT

Figure 8

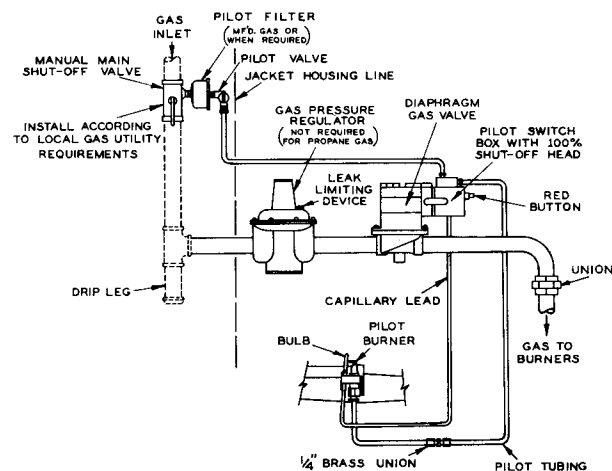

PIPE SHOWN IN DOTTED LINE NOT SUPPLIED

Figure 9

#### MINNEAPOLIS HONEYWELL PILOT

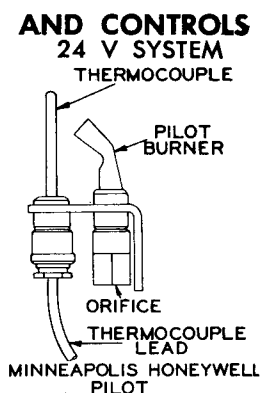
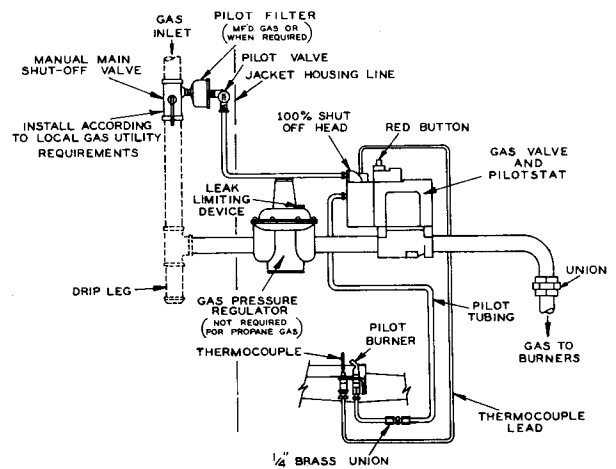

Figure 10



PIPE SHOWN IN DOTTED LINE NOT SUPPLIED

Figure 11

### CONNECTING THE GAS CONTROLS OF M-H POWERPILE SYSTEM

1. Connect the control assembly to the manifold by means of the union. See Figure 13.
2. Connect the thermopile terminals to the gas valve according to the wiring diagram supplied.
3. Connect the bleed line from the gas valve to the unmarked tubing under the manifold. See Figure 13.
4. Connect the gas line to the meter. The manual main shut-off valve should be installed in accordance with local utility company requirements. A trap must be installed at the inlet of the gas connection to the unit to satisfy A.G.A. requirements.
5. Connect the pilot tubing from the pilot cock to the tubing marked "pilot tubing" below the manifold. (See Figure 13.)
6. Check all gas connections for leaks. Use a soapy solution -- do not use a flame. Liability for damage done through the use of a flame when testing for gas leaks cannot be assumed by the manufacturer.

### WIRING THE BOILER

1. Install the high limit-circulator control in its well that was previously installed in the boiler. The control should be mounted horizontal in its final position. See Figure 14.
2. Position the wiring harness with the junction box attached on the proper side panel closest to the high limit-circulator control, lining it up with knockouts in the jacket side panel. Remove the two knockouts in both the junction box and the jacket side panel. See Figure 14.
3. Attach the junction box to the jacket side panel with the two screws provided. When screwed to the jacket the knockouts in the junction box will line up with the knockouts in the jacket.
4. Remove the lower knockout in the high limit-circulator control and connect the wiring harness elbow. See Figure 14.
5. Connect one end of the short length of wiring harness from the outside through the jacket and into the lower knockout. The other end of the harness is to be attached to the circulator.
6. This short wiring harness will fit most circulators when they are attached to the boiler with a 1 1/4" x 2 1/2" nipple. See Figure 14. If the circulator is to be located in some other location the additional length of harness required must be supplied by the installer.
7. Install the transformer on the junction box. Omit this step and install the junction box cover if equipped with Powerpile.
8. Wire the controls according to the printed wiring diagram supplied with the boiler. It is important to follow the color code wiring so that the controls will work properly.
9. The upper 7/8" knockout on the jacket side panel over the junction box is for the 115V power supply.

### M-H POWERPILE PILOT AND CONTROLS SELF GENERATING SYSTEM

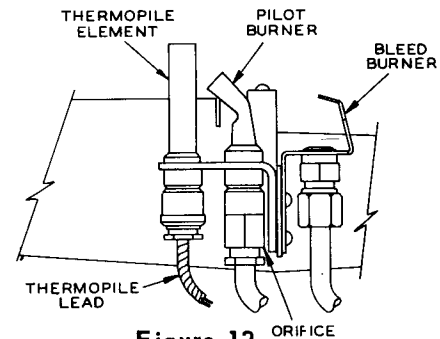

Figure 12

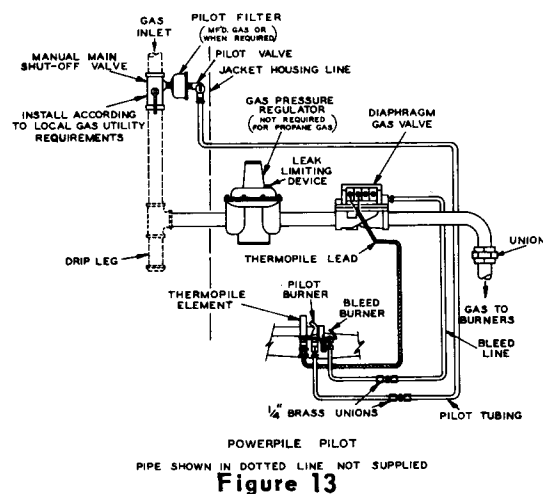
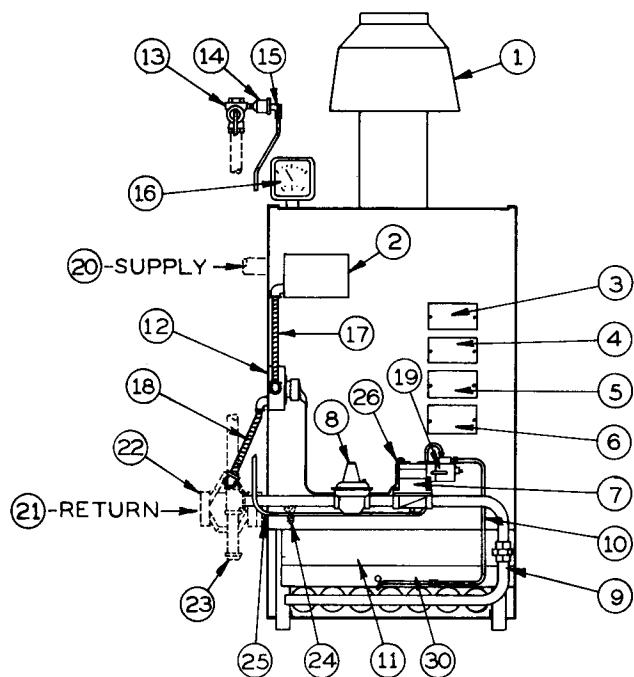
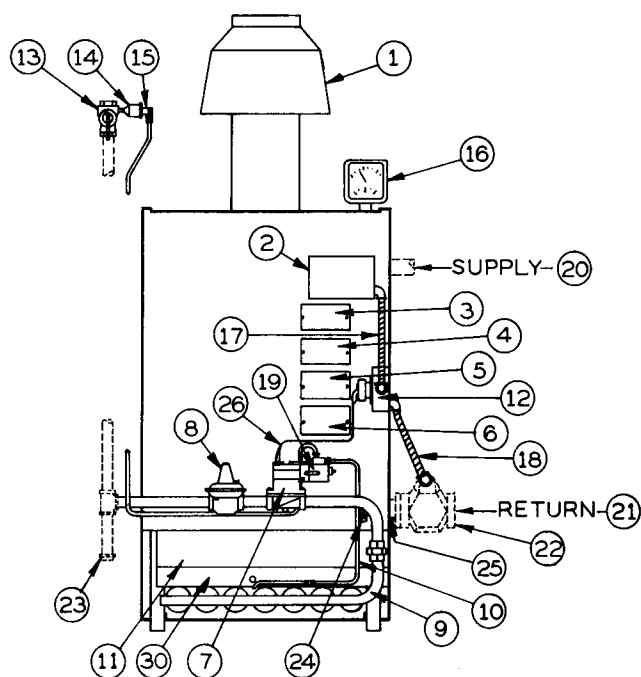

Figure 13





LEFT HAND  
SUPPLY AND RETURN



RIGHT HAND  
SUPPLY AND RETURN

## 24V SYSTEM

### PARTS SUPPLIED

- (1) Draft Hood
- (2) High Limit & Circulator Control
- (3) A.G.A. Rating Plate
- (4) Operating Instruction Plate
- (5) Wiring Plate
- (6) Alcove Clearance Plate
- (7) Main Gas Valve
- (8) Pressure Regulator
- (9) Manifold
- (10) Pilot Tubing
- (11) Front Panel
- (12) Junction Box & Transformer
- (13) Manual Main Shut-off Valve
- (14) Pilot Filter (Mf'd. or Nat. Gases if req'd. by utility)
- (15) Pilot Cock
- (16) Combination Pressure, Temperature and Altitude Gauge
- (17) Wiring Harness with Junction Box
- (18) Wiring Harness to Circulator
- (19) Plug In Pilot with 100% Shut-off
- (26) Low Voltage Wire
- (27) Bleed Line
- (28) Junction Box Only
- (29) Strain Relief Fitting
- (30) Access Panel

### PARTS NOT SUPPLIED

- (20) Supply Piping
- (21) Return Piping
- (22) Circulator
- (23) Drip Leg
- (24) Drain Cock
- (25) 1/4 x 2 1/2 Nipple

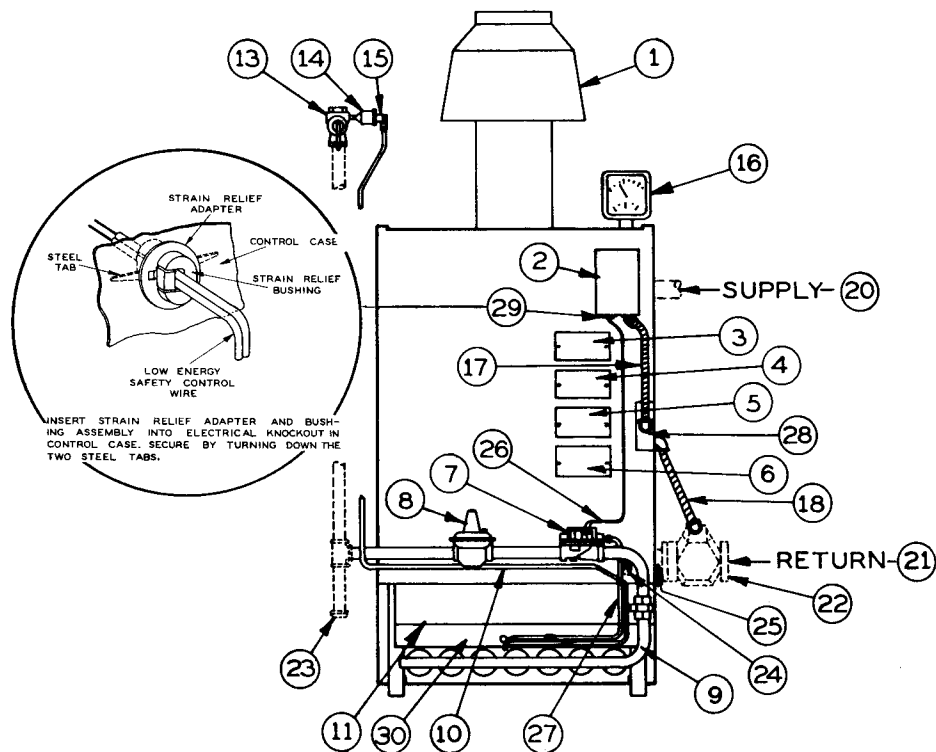

## POWERPILE SYSTEM (SELF GENERATING)

Figure 14

**STARTING UP SYSTEM FOR ALL GASES**

- A. The following prelighting steps are recommended to insure all around safety.
1. Fill system with water. See home owners card for instructions.
  2. Turn off main electric switch.
  3. Purge the air from the main gas line.
  4. Check all piping for gas leaks.

**CAUTION -- Allow boiler to ventilate for 5 minutes after checking piping for gas leaks. TO CHECK FOR GAS LEAKS, USE A SOAPY SOLUTION, DO NOT USE A FLAME. Liability for damage done through the use of a flame when testing for gas leaks cannot be assumed by the manufacturer.**

- B. Start up boiler following the lighting steps outlined on the instruction plate attached to the jacket.

**ADJUSTING THE BURNERS**

Proper adjustment of the primary air shutters on the burners is essential for correct performance. Avoid a hard flame that burns close to the burners by proceeding as follows with each shutter:

1. Adjust the primary air shutter by closing until yellow tips appear on the flame.
2. Then, open the shutter **very slowly** until the yellow tips just disappear from the flame.
3. Lock the shutter in this position by tightening the shutter retaining screw securely.

Measure the gas input to the boiler by reading the meter. Be sure all other appliances connected to the same meter are shut off.

$$\frac{\text{Cu. ft of Gas}}{\text{Minutes (at Meter)}} \times 60 \text{ minutes-hr.} \times \text{heating}$$

value of gas in BTU-cu.ft. = BTU-hr. boiler input.  
Compare to boiler input shown on boiler name plate.

If it is within 5% adjust pressure regulator to obtain the desired flow (stem for adjustment is under the cap on top of the regulator). **TURN STEM CLOCKWISE TO INCREASE AND COUNTER-CLOCKWISE TO DECREASE THE RATE.** If rate is more than 5% off of rated input, change orifice sizes. Check the burners again and readjust the flames if necessary.

**NOTE:** For proper aspiration, the manifold gas pressure should be about 2-1/2 inches of water column for manufactured gas, 3 to 3-1/2 inches for natural gas and 11 inches for Propane gas.

**ADDITIONAL INSTRUCTIONS**

**Important:** Before leaving job, make sure unit checks electrically.

1. Set the room thermostat above room temperature so that unit will start.
  2. When unit has operated for about 5 to 10 minutes, allowing the boiler water temperature to rise to about 120° to 130°F., then turn the high limit control setting below the boiler water temperature. The burners should go out then turn the high limit control up above the boiler water temperature the burner should ignite. Then, set the high limit control to the desired maximum boiler water temperature.
  3. The circulator control setting should be 100°F. to 120°F. The circulator will start operation as soon as the boiler temperature rises to the circulator control setting. The circulator will continue to operate until the water temperature drops to the setting of the circulator control thus providing a fully automatic control system.
  4. Set the room thermostat to desired room temperature.
  5. Make sure that the primary air shutters are tightened in a fixed position, so that they will not be subject to an accidental change in position.
- For additional information on controls, see control sheets supplied with boiler.

WHEN BOILER IS USED WITH REFRIGERATION SYSTEM

When boiler is used in connection with refrigeration systems, it shall be installed so that the chilled medium is piped in parallel with the heating boiler and with appropriate valve to prevent the chilled medium from entering the heating boiler.

When hot water heating boilers are connected to heating coils located in air handling units where they may be exposed to refrigerated air circulation, the boiler piping system shall be equipped with flow control valves or other automatic means to prevent gravity circulation of the boiler water during the cooling cycle.

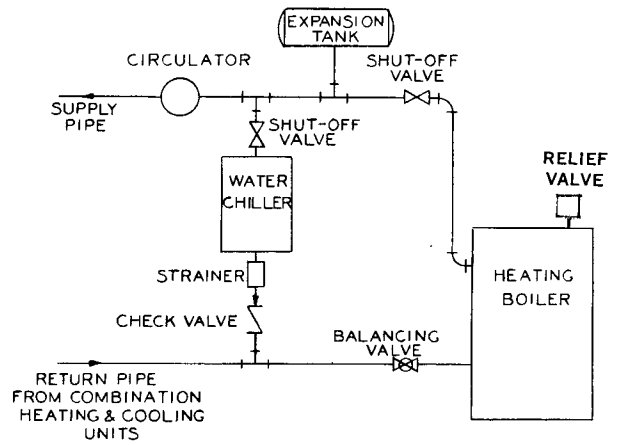

Figure 15

OVER FOR "SIZE OF PIPE TO GAS BOILERS"

**SIZE OF PIPING TO GAS BOILERS**

In determining the size of gas pipe, the following factors should be considered:

- a. Length of pipe and number of fittings.
- b. Maximum gas consumption to be provided for (including possible future expansion).
- c. Allowable loss in pressure from meter outlet to boiler. This is specified as three-tenths of an inch, water column.

The volume to be used (in cubic feet per hour) shall

be determined, whenever possible; directly from the BTU ratings of the boiler which will be installed and the heating value of the gas to be used. To obtain the cubic feet per hour, divide the total BTU input of the boiler by the BTU heating value per cubic foot of gas.

For 604 BTU gas allow 1.7 cubic feet and for natural gas allow .96 cubic feet for each 1000 BTU. See table below for determining the capacity of pipes of various diameters and lengths.

**PIPE DELIVERY SCHEDULE**

*\*Capacity of Pipes in Cubic Feet of Gas per Hour*

<i>Length of Pipe in Feet</i>	<b>SIZE</b>			
	<i>1/2 "</i>	<i>3/4 "</i>	<i>1 "</i>	<i>1 1/4 "</i>
10	132	278	520	1050
20	92	190	350	730
30	73	152	285	590
40	63	130	245	500
50	56	115	215	440
75	45	93	175	360
100	38	79	150	305
150	31	64	120	250

*\* Flow determined by Dr. Pole's Formula -- Specific Gravity: .60      Pressure Loss: 3/10" water.*

**ADDITIONAL LENGTH OF PIPE TO BE ADDED FOR EACH ELBOW OR TEE BEND IN THE LINE**

<i>Pipe Size, Inches</i>	<i>Additional Length, Feet</i>
1/2 . . . . .	1.3
3/4 . . . . .	1.7
1 . . . . .	2.2
1-1/4 . . . . .	2.9



**WEIL-McLAIN COMPANY, INC.**

MICHIGAN CITY • INDIANA